

Barrow County Board of Commissioners

30 North Broad Street Winder Georgia 30680 Phone: (770) 867-1977 Fax: (770) 307-3141

Cindy F. Clack
Purchasing Agent



MEMORANDUM – ADDENDUM NO. 1

To: Interested Vendors

From: Cindy Clack

Date: 7/10/2015

Re: RFB2015-17 – Ballfield Fencing – Victor Lord Park – Addendum No. 1

The following information has been submitted for RFB2015-17:

1. There have been some changes to the site plan. Please see the REVISED site plan C-1.1 (1 Page) that is attached.
2. Project Completion will be three (3) weeks from date of executed agreement by the Board of Commissioners.

BARROW COUNTY RECREATION VICTOR LORD PARK BALLFIELD FENCING - July 09 2015

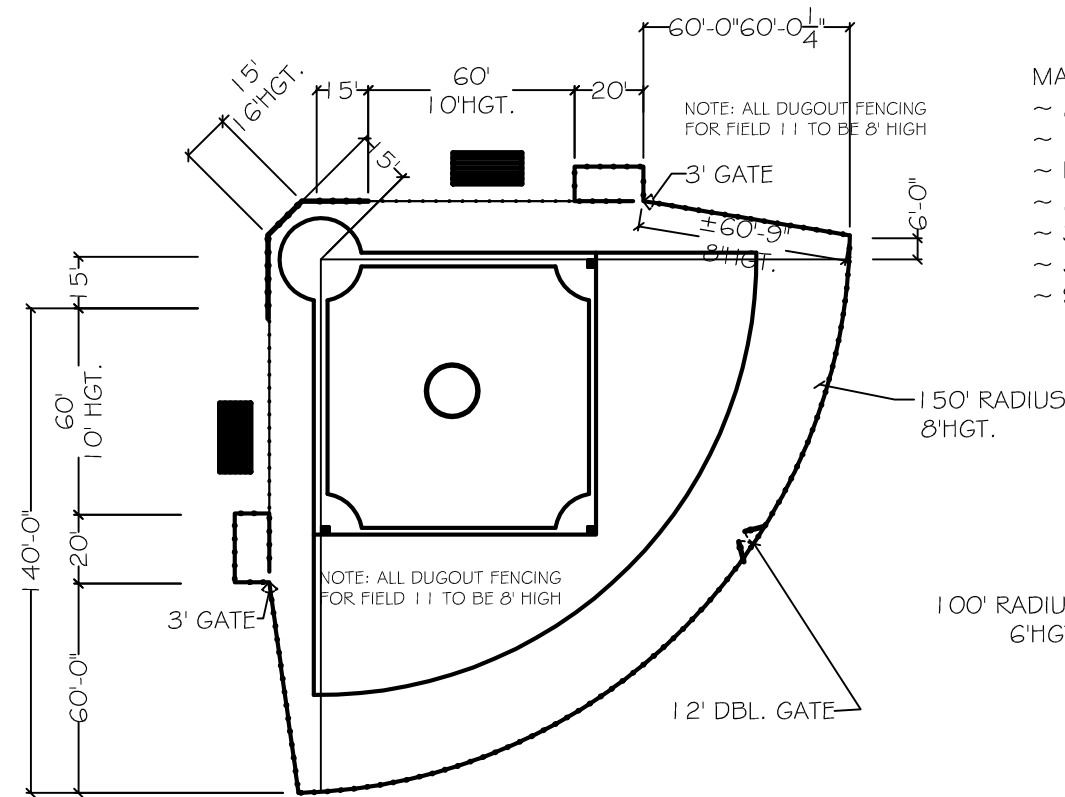

FIELD 11

- MATERIALS**
- ~ 2" X 9 GAUGE GALVANIZED CHAIN LINK FENCE
 - ~ 1-5/8" TOP AND BRACE RAILS 5 INTERMEDIATE
 - ~ RAILS IN DUGOUTS AND BACK STOP
 - ~ 2-1/2" SCHEDULE 40 PIPE LINE POST
 - ~ 3" SCHEDULE 40 TERMINAL, GATE AND PULL POST
 - ~ 3" SCHEDULE 40 X24" PIPE POST FOR BACK STOP
 - ~ 9 GAUGE SPRING COIL BOTTOM TENSION WIRE

- LINIER FEET OF FENCE**
- #9 ~ 472' X 6'HGT. FENCE ~ (2) 3' GATES, (1) 12' DBL. GATE
 - #10 ~ 472' X 6'HGT. FENCE ~ (2) 3' GATES, (1) 12' DBL. GATE
 - #11 ~ 45' X 16'HGT. FENCE
120' X 10'HGT. FENCE
475' X 8'HGT. FENCE ~ (2) 3' GATES, (1) DBL. GATE

COUNTY PROVISION
250' X 8' FENCE ~ (1) 12' DBL. GATE

ALL FENCE FOR FIELDS 9 & 10 TO BE 6'

FIELD 10

FIELD 9

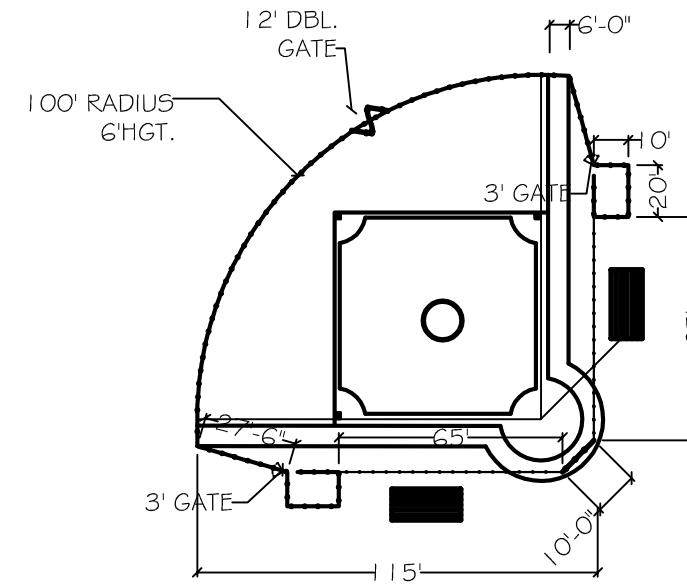
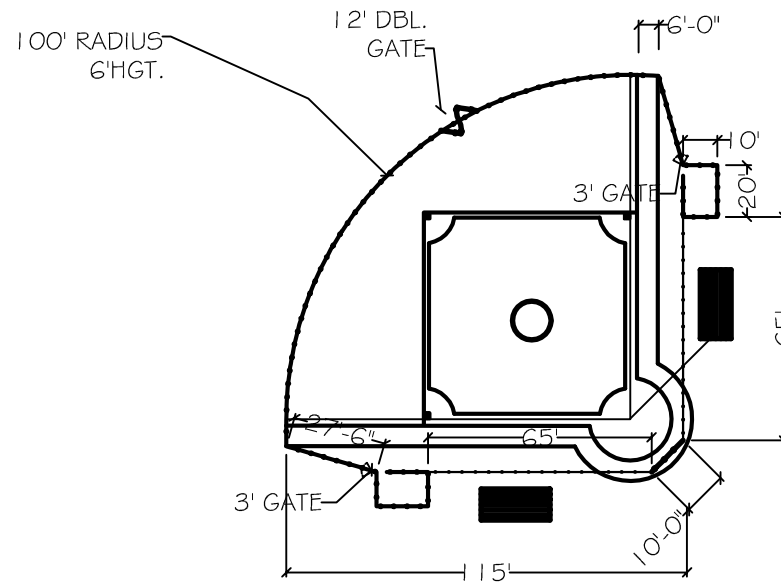

ALL FENCE FOR FIELDS 9 & 10 TO BE 6'



REVISIONS					
Number	Date	Remarks	Number	Date	Remarks

CONSULTANTS	

SEAL

SEAL

BARROW COUNTY RECREATION
VICTOR LORD PARK
Winder, Georgia

SHEET TITLE:
SITEPLAN
PRINTED: 00/00/00
path: \\server\shared\cad\...

NUMBER:
C-1.1

THIS DOCUMENT IS THE PROPERTY OF CARTER WATKINS ASSOCIATES. REPRODUCTION OF ANY KIND IS PROHIBITED UNDER FEDERAL COPYRIGHT LAWS. NOT ISSUED FOR CONSTRUCTION. DATE: 00/00/00